

Plain bearings — Wrapped bushes —

Part 5: Checking the outside diameter

National foreword

This British Standard is the UK implementation of ISO 3547-5:2007. It supersedes BS 4480-9:1995 which is withdrawn.

The UK participation in its preparation was entrusted to Technical Committee MCE/12, Plain bearings.

A list of organizations represented on this committee can be obtained on request to its secretary.

This publication does not purport to include all the necessary provisions of a contract. Users are responsible for its correct application.

Compliance with a British Standard cannot confer immunity from legal obligations.

This British Standard was published under the authority of the Standards Policy and Strategy Committee on 30 November 2007

© BSI 2007

ISBN 978 0 580 56483 3

Amendments issued since publication

Amd. No.	Date	Comments

INTERNATIONAL
STANDARD

ISO
3547-5

First edition
2007-10-01

Plain bearings — Wrapped bushes —

Part 5:
Checking the outside diameter

Paliers lisses — Bagues roulées —

Partie 5: Contrôle du diamètre extérieur



Reference number
ISO 3547-5:2007(E)

Contents

Page

Foreword.....	iv
1 Scope	1
2 Normative references	1
3 Symbols and units	2
4 Outside diameter, D_o	2
5 Purpose of checking.....	3
6 Methods of checking	3
7 Selection of checking method for outside diameter	3
8 ISO 3547-2, test A — Outside diameter, D_o	3
9 ISO 3547-2:2006, test B — Outside diameter, D_o.....	11
10 ISO 3547-2:2006, test D — Outside diameter, $D_o > 120$ mm.....	13
11 Specifications on drawings of bushes	14
12 Specifications for control of the checking equipment.....	14
Bibliography	15

Foreword

ISO (the International Organization for Standardization) is a worldwide federation of national standards bodies (ISO member bodies). The work of preparing International Standards is normally carried out through ISO technical committees. Each member body interested in a subject for which a technical committee has been established has the right to be represented on that committee. International organizations, governmental and non-governmental, in liaison with ISO, also take part in the work. ISO collaborates closely with the International Electrotechnical Commission (IEC) on all matters of electrotechnical standardization.

International Standards are drafted according to the rules given in the ISO/IEC Directives, Part 2.

Draft International Standards adopted by the technical committees are circulated to the member bodies for voting. Publication as an International Standard requires approval by at least 75 % of the member bodies casting a vote.

Attention is drawn to the possibility that some of the elements of this document may be the subject of patent rights. ISO shall not be held responsible for identifying any or all such patent rights.

International Standard ISO 3547-5 was prepared by Technical Committee ISO/TC 123, *Plain bearings*, Subcommittee SC 5, *Quality analysis and assurance*.

This part of ISO 3547 cancels and replaces ISO 12307-1:1994, which has been technically revised.

ISO 3547 consists of the following parts, under the general title *Plain bearings — Wrapped bushes*:

- *Part 1: Dimensions*
- *Part 2: Test data for outside and inside diameters*
- *Part 3: Lubrication holes, grooves and indentations*
- *Part 4: Materials*
- *Part 5: Checking the outside diameter*
- *Part 6: Checking the inside diameter*
- *Part 7: Measurement of wall thickness of thin-walled bushes*

Plain bearings — Wrapped bushes —

Part 5: Checking the outside diameter

1 Scope

This part of ISO 3547 specifies, following ISO 12301, the checking of the outside diameter of wrapped bushes (ISO 3547-2:2006, methods A, B and D) and describes the necessary checking methods and measuring equipment.

Wrapped bushes in the free condition are flexible, but after insertion they adapt largely to the shape of the housing bore due to the oversize between the outside diameter of the bush and the housing bore. For this reason, checking of the outside diameter of wrapped bushes can only be carried out under a constraining load by use of specialized measuring equipment.

NOTE 1 The dimensions and tolerances of wrapped bushes are given in ISO 3547-1. Checking the wall thickness is the subject of ISO 3547-7.

2 Normative references

The following referenced documents are indispensable for the application of this document. For dated references, only the edition cited applies. For undated references, the latest edition of the referenced document (including any amendments) applies.

ISO 286-2:1988, *ISO system of limits and fits — Part 2: Tables of standard tolerance grades and limit deviations for holes and shafts*

ISO/R 1938-1:1971, *ISO system of limits and fits — Part 1: Inspection of plain workpieces*

ISO 3547-2:2006, *Plain bearings — Wrapped bushes — Part 2: Test data for outside and inside diameters*

3 Symbols and units

Table 1 — Symbols and units

Symbol	Parameter	SI unit
B	Width of the bush	millimetres
$b_{ch, 1}$	Width of the checking block	millimetres
$b_{ch, 2}$	Width of the setting plug	millimetres
d_o	Outside diameter of the ring gauge	millimetres
D_o	Outside diameter of the bush	millimetres
$d_{ch, 1}$	Diameter of the checking block bore (see ISO 3547-2)	millimetres
$d_{ch, 2}$	Diameter of the setting plug (see ISO 3547-2)	millimetres
$d_{ch, a, 1}$	Actual diameter of the checking block	millimetres
$d_{ch, a, 2}$	Actual diameter of the setting plug	millimetres
F_{ch}	Checking load	newtons
C	Correction factor	millimetres
n	Number of test pieces	—
R_a	Surface roughness	micrometres
$t_1 \dots t_6$	Tolerances of form and position	millimetres
x	Length of checking block	millimetres
y	Width of checking block	millimetres
z	Distance between checking block halves	millimetres
ΔD_o	Tolerance of D_o	millimetres
Δz	Indicator reading	millimetres
Δz_D	Circumference indicator reading	millimetres

4 Outside diameter, D_o

For the outside diameter of a wrapped bush, see Figure 1.

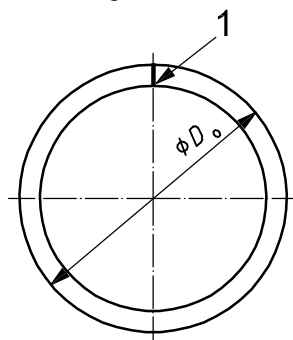

Key

1 split line

NOTE The free diameter of a wrapped bush is not measured directly because of the flexible nature of the component.

Figure 1 — Outside diameter of a wrapped bush

5 Purpose of checking

The outside diameter shall be checked to ensure the designated mounting compression (interference fit) for the wrapped bush in the housing bore.

6 Methods of checking

NOTE Checking method C is for measuring the inside diameter and is covered by ISO 3547-6.

6.1 Checking method A — Measurement of outside diameter, D_o

NOTE See ISO 3547-2.

Check the outside diameter of a wrapped bush using measuring equipment as shown in Figure 2, with a checking block consisting of upper and lower halves (see Figures 3 and 4) and setting plugs (see Figures 5 and 6), at a determined checking load, F_{ch} .

Measure the outside diameter indirectly as the difference in the value of z , Δz .

The checking load is calculated so that the bush outside diameter is reduced only elastically during checking and that there is no permanent deformation.

6.2 Checking method B — Gauging of outside diameter, D_o

NOTE See ISO 3547-2.

Check the outside diameter of a wrapped bush in “GO” and “NO GO” ring gauges.

6.3 Checking method D — Measurement of outside diameter, $D_o > 120$ mm

NOTE See ISO 3547-2.

Check the outside diameter of a wrapped bush above 120 mm diameter using a precision measuring tape.

7 Selection of checking method for outside diameter

Method A is a precise method involving complex tooling. Method B is an attributive method using simpler tooling. Method D is used only for wrapped bushes with an outside diameter > 120 mm. All three methods are in general use. Method A is generally unsuitable for small bushes up to 10 mm outside diameter but is preferred for bushes over 10 mm outside diameter.

8 ISO 3547-2, test A — Outside diameter, D_o

8.1 Measuring equipment

See Tables 2 and 3.

Typical equipment for measuring the bush consists essentially of the following components:

- base plate used as fixture and guiding device for the split checking block;
- means to generate the checking load;
- means to calibrate the load;

- upper plate;
- system for transmitting the distance, z , of both checking block halves to the measuring pin (see Figure 2);
- measuring pin with indicating instrument;
- checking block (see Figures 3 and 4) with setting plug (see Figures 5 and 6).

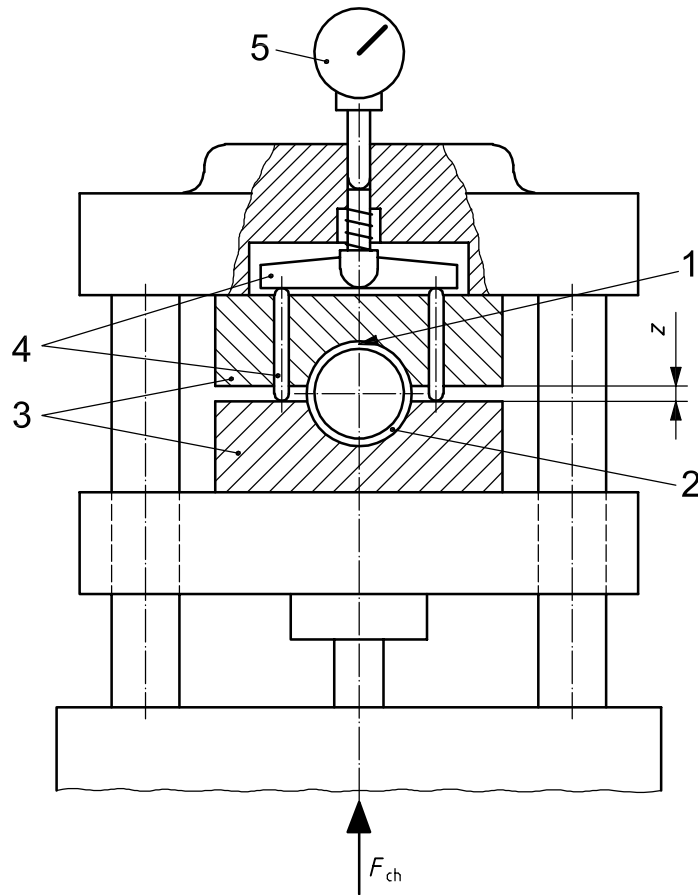

- Key**
- 1 split line
 - 2 bush
 - 3 checking block
 - 4 measuring pins
 - 5 indicating instrument

Figure 2 — Typical outside diameter measuring system

Figure 2 shows a typical outside diameter measuring system. This may be operated hydraulically, pneumatically or mechanically.

The force, F_{ch} , may be smoothly applied from the top or from below.

The bush split shall be in the vertical direction and pointing towards the upper checking block.

Table 2 — Checking loads, limiting deviations, speed of approach and temperature

Checking load F_{ch} N		Permissible limiting deviations %	Maximum speed of approach to apply the checking load, F_{ch} mm/s	Test temperature ^a °C
—	≤ 2 000	± 1,25	12	20 to 25
> 2 000	≤ 5 000	± 1		
> 5 000	≤ 10 000	± 0,75		
> 10 000	≤ 50 000	± 0,5		

^a The difference in temperature between the checking block and the bush to be measured shall not exceed 1 °C.

Table 3 — Deviations for dial gauge and electronic gauge

Dimensions in millimetres

Outside diameter Tolerance ΔD_o		Resolution		Total deviation ^a	
		dial gauge	electronic gauge	dial gauge	electronic gauge
—	≤ 0,1	0,001	0,001	0,001 2	0,5 % of measuring range
> 0,1		0,005	0,005	0,006	

^a Maximum measuring value indication (for a full-scale range of ± 500 µm).

8.2 Requirements for checking the block and the setting plug

The requirements for the checking block and the setting plug for measuring the bush outside diameter, D_o , shall be as shown in Figures 3 to 6 and as given in Table 4. Manufacturing tolerances and wear limits are given in Table 5.

Table 4 — Maximum difference between the diameters of the checking block, $d_{ch, 1}$, and setting plug, $d_{ch, 2}$, for a usable combination

Dimensions in millimetres

D_o nominal		$d_{ch, 1} - d_{ch, 2}$ max.
	≤ 18	0,006
> 18	≤ 50	0,008
> 50	≤ 80	0,01
> 80	≤ 120	0,012
> 120	≤ 180	0,016

Dimensions in millimetres

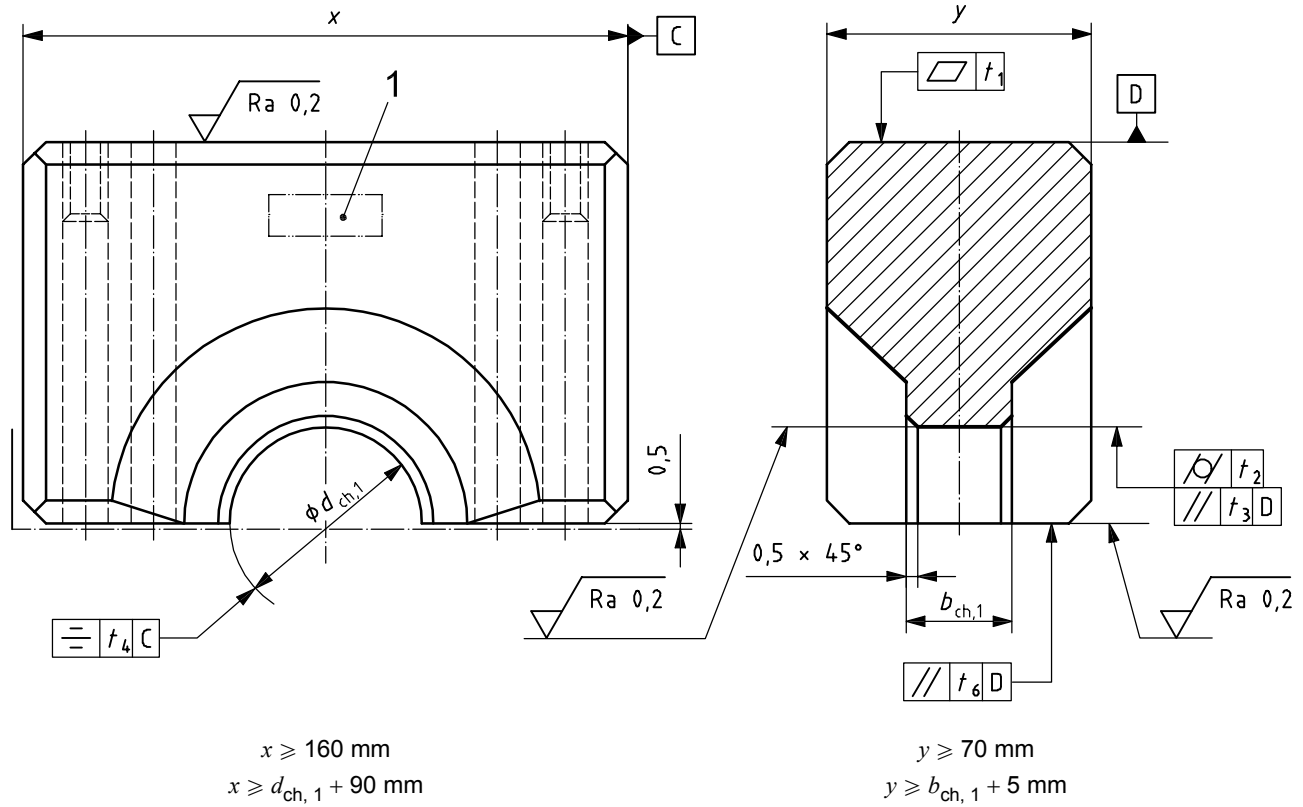

Key

- 1 field for marking
- $b_{ch,1} \geq B + 2$

Figure 3 — Upper half of checking block

Dimensions in millimetres, unless otherwise indicated

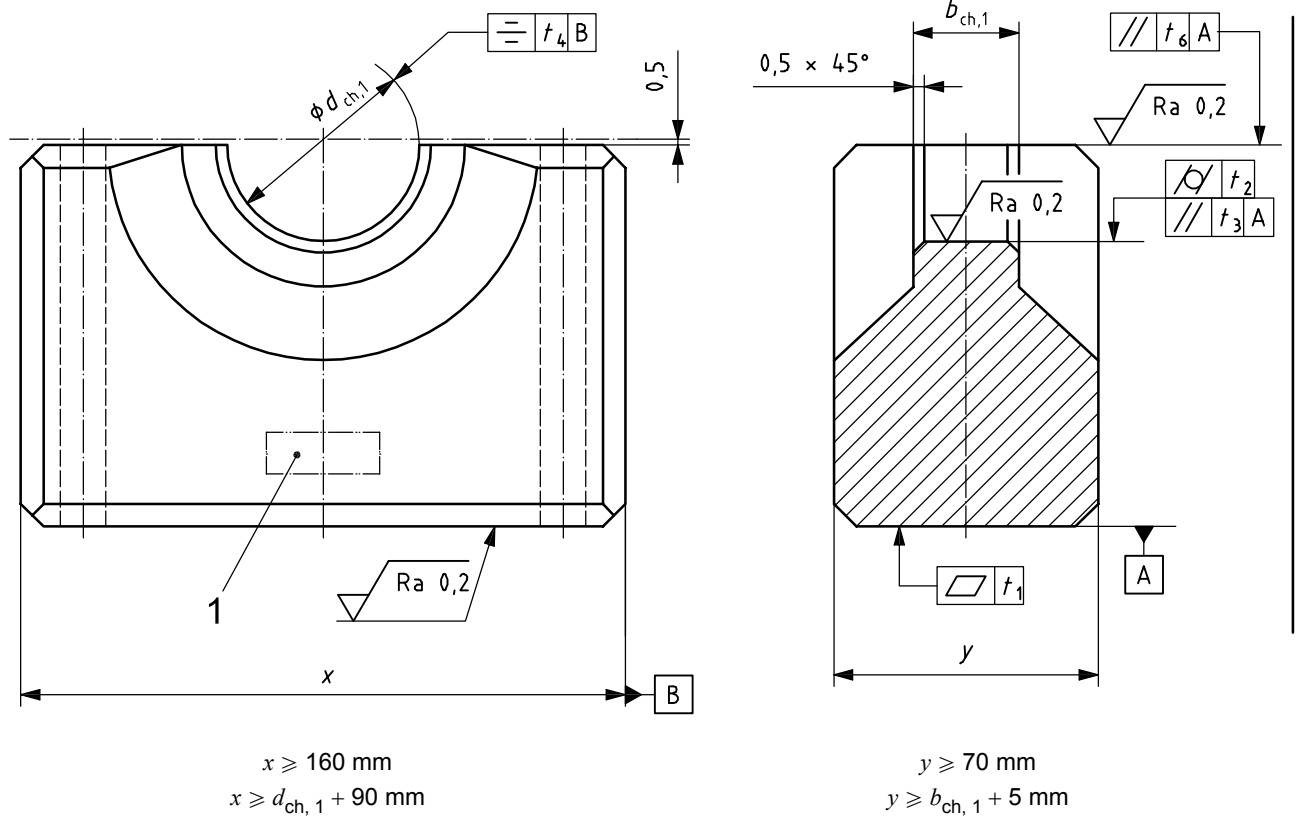

Key

- 1 field for marking
- $b_{ch,1} \geq B + 2$

Figure 4 — Lower half of checking block

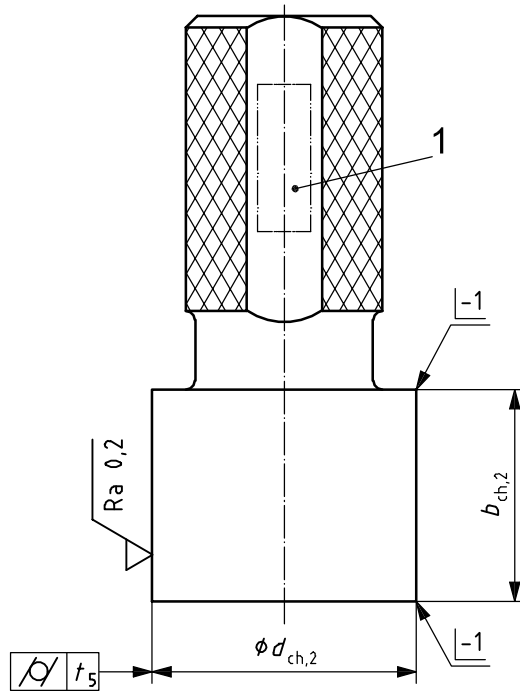

Key
 1 field for marking
 $b_{ch,2} \geq b_{ch,1} + 5$

Figure 5 — Setting plug, solid, for $d_{ch,2} \leq 80$ mm

Dimensions in millimetres

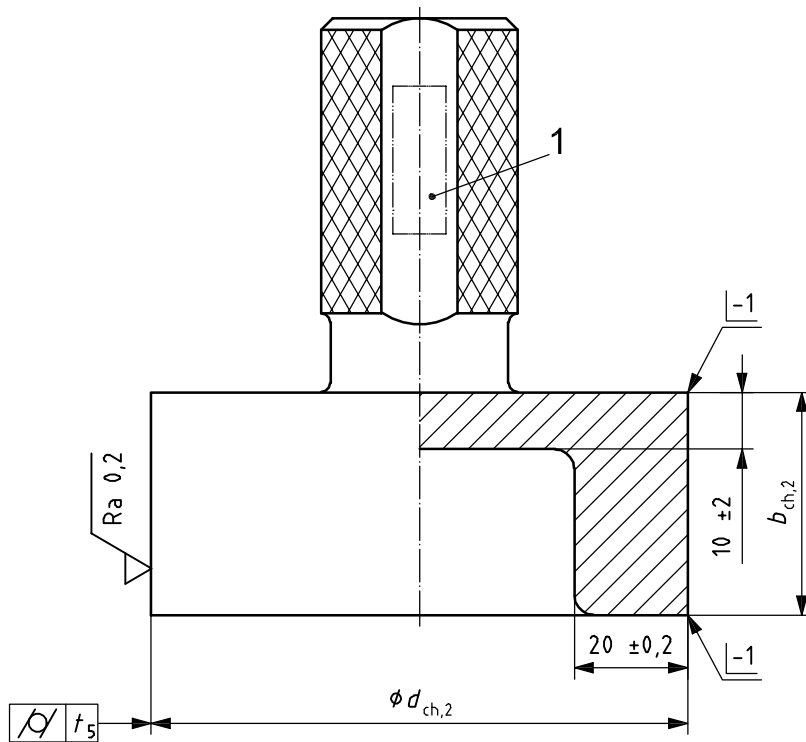

Key
 1 field for marking
 $b_{ch,2} \geq b_{ch,1} + 5$

Figure 6 — Setting plug, for example with blind hole, for $d_{ch,2} > 80$ mm

Table 5 — Manufacturing tolerances and wear limits for checking block, setting plug and ring gauge

Dimensions in millimetres

D_o nominal		Limits of manufacturing tolerances or wear limits	$d_{ch, 2}$	$d_{ch, 1}$	t_1	t_2	t_3	t_4	t_5	t_6
≤ 80		manufacture	$\begin{matrix} 0 \\ -0,003 \end{matrix}$	$\begin{matrix} +0,003 \\ 0 \end{matrix}$	0,002	0,002	0,003	0,05	0,002	0,03
		wear	-0,005	+0,005	0,004	0,004	0,005	0,05	0,004	0,05
> 80	$\leq 150^a$	manufacture	$\begin{matrix} 0 \\ -0,005 \end{matrix}$	$\begin{matrix} +0,005 \\ 0 \end{matrix}$	0,003	0,003	0,004	0,05	0,003	0,03
		wear	-0,007	+0,007	0,005	0,005	0,006	0,05	0,005	0,05

^a For $D_o > 150$ mm agreement shall be reached between the supplier and user.

Checking block halves (see Figures 3 and 4) and setting plugs (see Figures 5 and 6) shall be made from hardened (60 HRC to 64 HRC) and non-ageing steel.

The checking block halves shall be of rigid construction so that only negligible deformations are caused by the forces arising during measurement of the bushes.

The bore of the checking block halves and the checking surface of the setting plug shall not be chromium plated.

The checking block diameter, $d_{ch, 1}$, and the setting plug diameter, $d_{ch, 2}$, may be marked with their nominal value.

8.3 Determination of correction factor, C

The correction factor, C , is used to correct the setup of the indicating instrument and is calculated from Equation (1):

$$C = \frac{\pi}{2} \left[\left(d_{ch,a,1} - d_{ch,1} \right) - \left(d_{ch,a,1} - d_{ch,a,2} \right) \right] \quad (1)$$

EXAMPLE

$$d_{ch,1} = 20,050 \text{ mm}$$

$$d_{ch,a,1} = 20,052 \text{ mm}$$

$$d_{ch,a,2} = 20,048 \text{ mm}$$

Therefore,

$$C = \frac{\pi}{2} (20,052 - 20,050) - (20,052 - 20,048)$$

$$C = -0,001 \text{ mm}$$

If the actual diameter, $d_{ch,a,1}$, of the checking block deviates from the checking block diameter, $d_{ch,1}$, of the bushes to be checked, these checking blocks may still be used provided that the deviation $|d_{ch,a,1} - d_{ch,1}| \leq 0,03$ mm. The tolerances of the setting plug according to Table 5 are not affected.

EXAMPLE

$$d_{\text{ch},1} = 20,062 \text{ mm}$$

$$d_{\text{ch},a,1} = 20,052 \text{ mm}$$

$$d_{\text{ch},a,2} = 20,048 \text{ mm}$$

$$|d_{\text{ch},a,1} - d_{\text{ch},1}| = 0,010 \text{ mm} = < 0,030 \text{ mm}$$

Therefore,

$$C = \frac{\pi}{2} (20,052 - 20,062) - (20,052 - 20,048)$$

$$C = -0,020 \text{ mm}$$

8.4 Procedure

Perfect positioning of both checking block halves is achieved when the following procedure is used. With the setting plug positioned and fixed centrally in the lower checking block, mount the upper checking block on the setting plug. Apply the checking load, F_{ch} and clamp in position.

Adjust the correction factor, C , in accordance with 8.3, remove the setting plug and insert the bush centrally with the split vertically upwards. Reapply the check load and take the indicator reading, Δz .

8.5 Measuring errors

The most frequent errors are given in 8.5.1 to 8.5.3.

8.5.1 Errors due to measuring equipment

- a) The upper and lower checking block halves are not aligned.
- b) The checking block halves are not correctly fixed in the measuring equipment.
- c) The tightness is not correct [too much clearance, damage of the transmitting system (see Figure 2), dial gauge, etc.].
- d) The checking block or setting plug is damaged or worn.
- e) The width of the checking block bore, $b_{\text{ch},1}$, is less than the width of the bush, B .
- f) The checking load, F_{ch} , does not correspond to the calculated load.

8.5.2 Errors due to the bush

Errors due to the bush are caused by the presence of grease, dirt, burrs, etc. on the outside diameter (back surface) and/or in the split, and damage or deformation of the outside diameter and/or the split.

8.5.3 Errors due to human factors

- a) The checking load is incorrectly set.
- b) The bush is not centralized in the checking block.
- c) The split in the bush is not pointed vertically towards the upper checking block.
- d) An incorrect reading is taken during measurement of the actual diameters, $d_{ch, a, 1}$ and $d_{ch, a, 2}$.
- e) The correction factor is incorrectly calculated and/or set.
- f) The outside diameter, D_o , is incorrectly calculated.

8.6 Summary of the factors relating to the measurement of the outside diameter, D_o , of the bush

8.6.1 Checking load, F_{ch}

The checking load, F_{ch} , shall be calculated in accordance with ISO 3547-2.

8.6.2 Diameter of the checking block, $d_{ch, 1}$, and of the setting plug, $d_{ch, 2}$

The diameter shall be calculated in accordance with ISO 3547-2.

8.6.3 Upper limiting value and lower limiting value for Δz

The upper limiting value is 0.

The lower limiting value is $-\Delta D_o \left(\frac{\pi}{2} \right)$, rounded up to 0,005 mm, where $\Delta D_o = D_{o, \max} - D_{o, \min}$.

8.6.4 Correction factor, C

The correction factor, C , shall be calculated in accordance with 8.3.

8.6.5 Conversion of the indicated measured value, Δz , for outside diameter

This conversion is calculated in accordance with ISO 3547-2.

9 ISO 3547-2:2006, test B — Outside diameter, D_o

9.1 Gauging equipment

The test is carried out by means of two ring gauges, one corresponding to the maximum limiting value (GO ring gauge), the other corresponding to the minimum limiting value (NO GO ring gauge) of the outside diameter, D_o , of the bush according to the drawing. Both ring gauges shall have a lead-in chamfer of narrow angle (see Figure 7) or radius in order to assist in the insertion of the bush and to avoid damage and failure during the test.

9.2 Requirements for measuring equipment

Ring gauges shall be of hardened (60 HRC to 64 HRC) and non-ageing steel. The width of the ring gauge (without chamfer) shall at least correspond to the maximum width of the bush.

The limiting values of the ring gauge inside diameter for a GO ring gauge and a NO GO ring gauge shall be in accordance with ISO 286-2:1988, tolerance class JS3.

Wear of the ring gauges shall not exceed the y_1 value (reference value for the wear limit) for work pieces IT 8 in accordance with ISO/R 1938-1.

Dimensions in millimetres, unless otherwise indicated

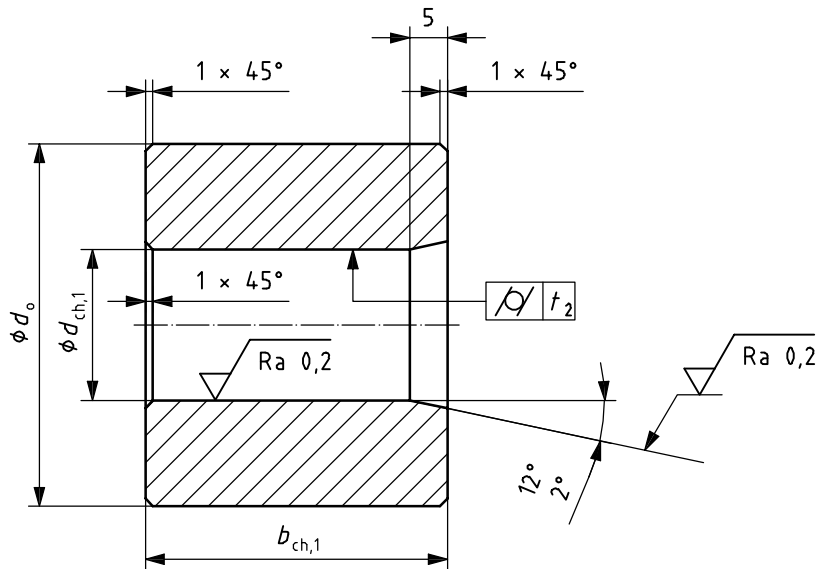

$$b_{ch,1} \geq B + 9$$

$$d_o \geq d_{ch,1} + 50$$

Figure 7 — Ring gauge

9.3 Procedure

Insert the bush into the GO ring gauge from the side having the lead-in chamfer. It shall be possible to introduce it and push it through the GO ring gauge by hand (maximum force 250 N) but not (with the same force) into the NO GO ring gauge.

In some cases, the accuracy of the test may be reduced if the bush is not round or the split not closed. Therefore, the test according to method A is preferred.

9.4 Measuring errors

The most frequent measuring errors are as follows.

- The ring gauges are damaged or worn.
- The ring gauges have no lead-in chamfer.
- The bushes are inserted into the ring gauge in an inclined position.
- The bushes are inserted into the ring gauge with too much force.
- The width of the ring gauge is less than the width of the bush.
- There is out-of-roundness and an open split of the bush in the free condition.
- Grease, dirt, burrs, etc., are present on the outside diameter (back surface) and/or in the split, or the outside diameter and/or the split is damaged or deformed.

10 ISO 3547-2:2006, test D — Outside diameter, $D_o > 120$ mm

10.1 Gauging equipment

The test is carried out by means of a precision measuring tape.

10.2 Measuring equipment

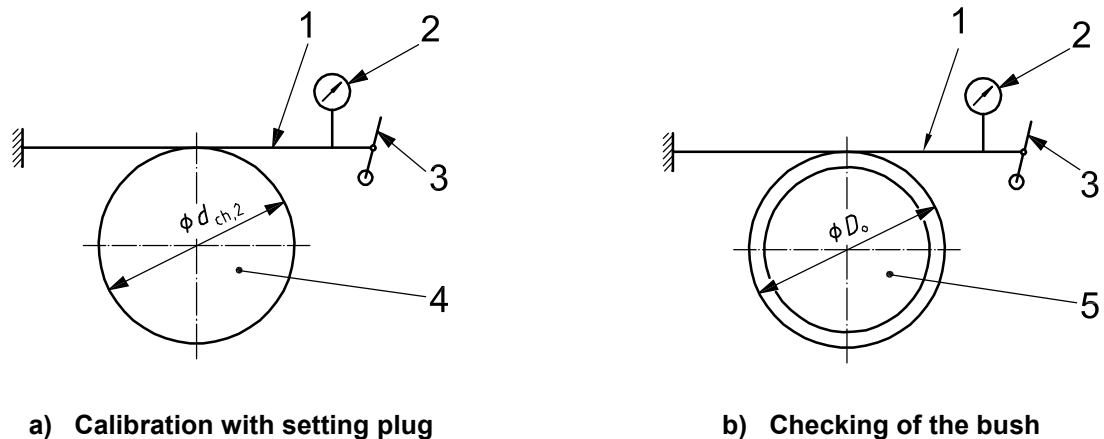

Key

- 1 precision measuring tape
- 2 dial gauge
- 3 tensioning handle
- 4 setting plug
- 5 bush

Figure 8 — Measuring equipment

10.3 Procedure

The measuring tape is calibrated around a plug with a diameter equal to the nominal outside diameter, D_o , of the bush. An indicating device is attached to the “free” end of the measuring tape and set to the calibration size.

After the bush has been checked, the circumference indicator reading, Δz_D , is the difference between the calibrated value of the setting plug and the measured value of the bush. From this, the outside diameter of the bush, D_o , can be calculated as given in Equation (2):

$$D_o = d_{ch,2} + \frac{\Delta z_D}{\pi} \quad (2)$$

10.4 Measuring errors

The most frequent measuring errors are as follows.

- a) The tension is not sufficient to close the split line.
- b) The measuring tape is not wrapped around the centre line of the bush.
- c) Grease, dirt, burrs, etc. are present on the outside diameter (back surface) and/or in the split, or the outside diameter and/or the split is damaged or deformed.

11 Specifications on drawings of bushes

The preferred option for the checking method shall be as specified as in ISO 3547-2.

12 Specifications for control of the checking equipment

12.1 Gauging equipment

The gauging equipment shall be checked regularly; significant damage shall be made good and any dimensional changes shall be recorded.

12.2 Measuring equipment

The measuring equipment shall be checked for accuracy, at time intervals that should be specified in accordance with statistical methods.

Bibliography

- [1] ISO 286-1, *ISO system of limits and fits — Part 1: Bases of tolerances, deviations and fits*
- [2] ISO 3547-1, *Plain bearings — Wrapped bushes — Part 1: Dimensions*
- [3] ISO 3547-6, *Plain bearings — Wrapped bushes — Part 6: Checking the inside diameter*
- [4] ISO 3547-7, *Plain bearings — Wrapped bushes — Part 7: Measurement of wall thickness of thin-walled bushes*
- [5] ISO 12301, *Plain bearings — Quality control techniques and inspection of geometrical and material quality characteristics*

BSI — British Standards Institution

BSI is the independent national body responsible for preparing British Standards. It presents the UK view on standards in Europe and at the international level. It is incorporated by Royal Charter.

Revisions

British Standards are updated by amendment or revision. Users of British Standards should make sure that they possess the latest amendments or editions.

It is the constant aim of BSI to improve the quality of our products and services. We would be grateful if anyone finding an inaccuracy or ambiguity while using this British Standard would inform the Secretary of the technical committee responsible, the identity of which can be found on the inside front cover.
Tel: +44 (0)20 8996 9000. Fax: +44 (0)20 8996 7400.

BSI offers members an individual updating service called PLUS which ensures that subscribers automatically receive the latest editions of standards.

Buying standards

Orders for all BSI, international and foreign standards publications should be addressed to Customer Services. Tel: +44 (0)20 8996 9001.
Fax: +44 (0)20 8996 7001. Email: orders@bsi-global.com. Standards are also available from the BSI website at <http://www.bsi-global.com>.

In response to orders for international standards, it is BSI policy to supply the BSI implementation of those that have been published as British Standards, unless otherwise requested.

Information on standards

BSI provides a wide range of information on national, European and international standards through its Library and its Technical Help to Exporters Service. Various BSI electronic information services are also available which give details on all its products and services. Contact the Information Centre.
Tel: +44 (0)20 8996 7111. Fax: +44 (0)20 8996 7048. Email: info@bsi-global.com.

Subscribing members of BSI are kept up to date with standards developments and receive substantial discounts on the purchase price of standards. For details of these and other benefits contact Membership Administration.
Tel: +44 (0)20 8996 7002. Fax: +44 (0)20 8996 7001.
Email: membership@bsi-global.com.

Information regarding online access to British Standards via British Standards Online can be found at <http://www.bsi-global.com/bsonline>.

Further information about BSI is available on the BSI website at <http://www.bsi-global.com>.

Copyright

Copyright subsists in all BSI publications. BSI also holds the copyright, in the UK, of the publications of the international standardization bodies. Except as permitted under the Copyright, Designs and Patents Act 1988 no extract may be reproduced, stored in a retrieval system or transmitted in any form or by any means – electronic, photocopying, recording or otherwise – without prior written permission from BSI.

This does not preclude the free use, in the course of implementing the standard, of necessary details such as symbols, and size, type or grade designations. If these details are to be used for any other purpose than implementation then the prior written permission of BSI must be obtained.

Details and advice can be obtained from the Copyright & Licensing Manager.
Tel: +44 (0)20 8996 7070. Fax: +44 (0)20 8996 7553.
Email: copyright@bsi-global.com.